

- K.2** General data, Installation notes
- K.4** Analog interface
- K.6** Digital pulse interface
- K.8** SSD interface

BTLK

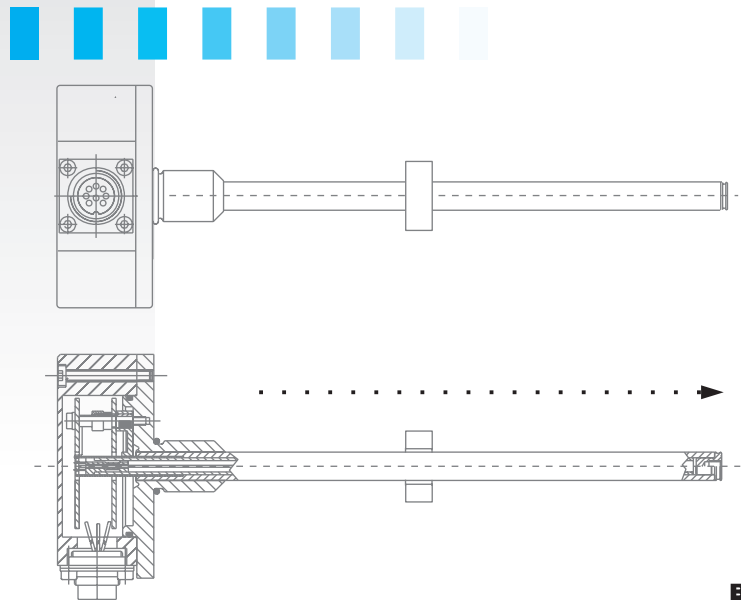

- General data
- Installation notes
- Analog interface
- Digital pulse interface
- SSD interface

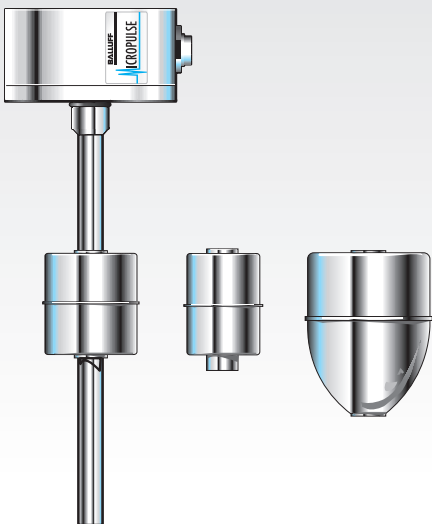
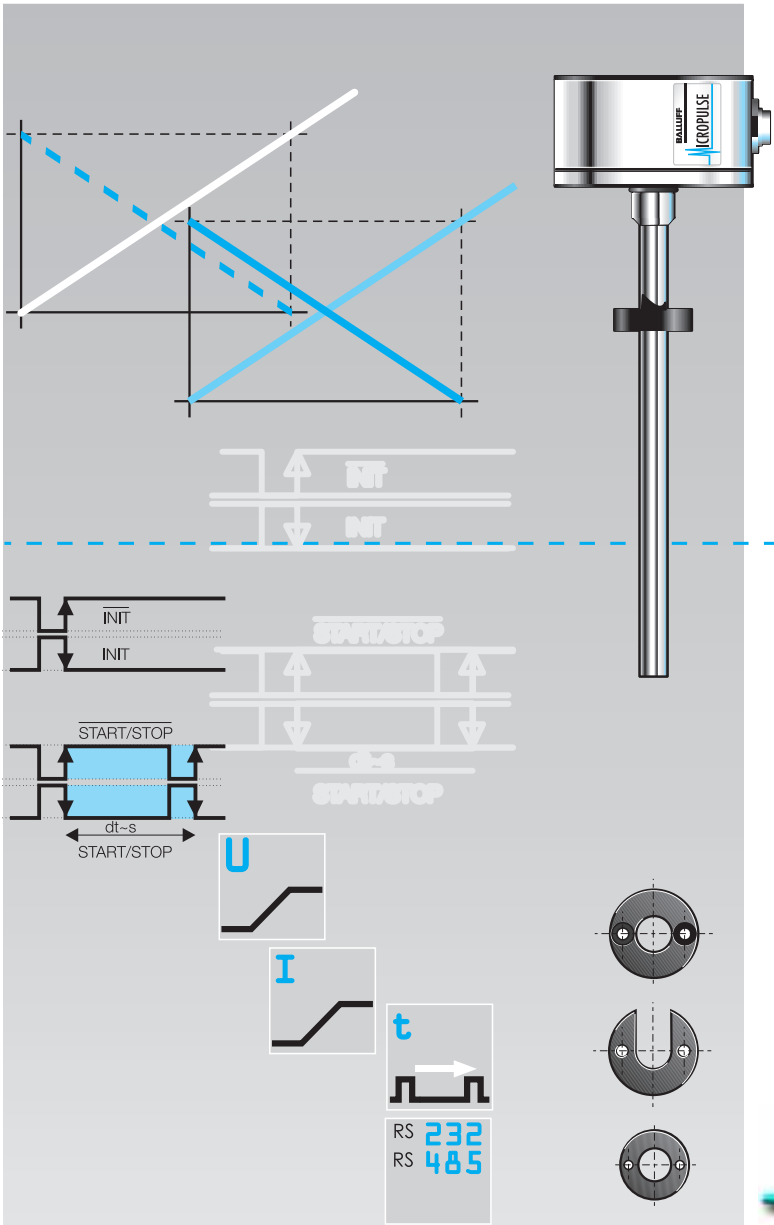

**Pressure rated to 600 bar,
high repeatability,
non-contact, rugged**

The Micropulse transducer is the rugged position feedback system for use in extreme ambient conditions and stroke ranges between 25 and 4000 mm.

The actual waveguide is enclosed in a protective, high-pressure resistant stainless steel tube. The system is ideally suited for use in hydraulic cylinders for position feedback or as a level detector in aggressive media in the food products and chemical industries.

- stainless
- extremely short 34 mm
- IP 68 with cable

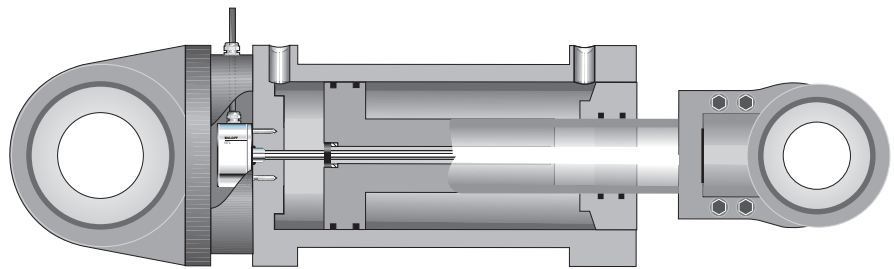

Compact Micropulse transducer installed in clevis mount cylinder

Installation

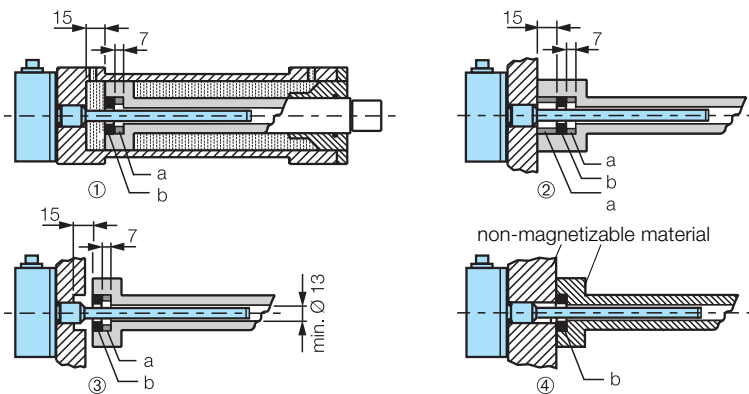

- ①–③ for magnetizable material
- ④ for non-magnetizable material
- a Spacer made of non-magnetizable material
- b Magnet

The Micropulse transducer has 6 mounting holes for cylinder head screws (ISO 4762 M6×18 A2-70). We recommend installing in non-magnetizable materials. If using magnetizable material, installation must be done as shown above. Sealing is at the flange mounting surface using a supplied 15.4 × 2.1 O-ring.

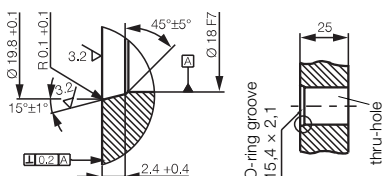
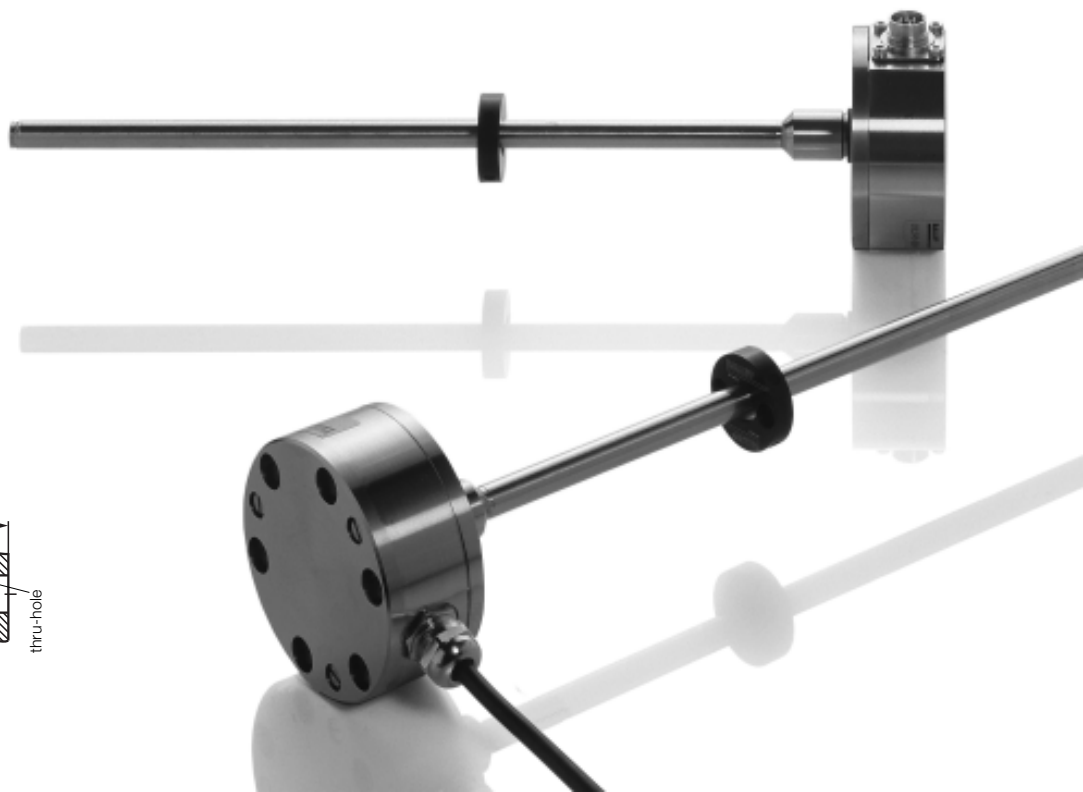

Compact Rod **Micropulse Transducers**

General data
Compact rod series

Baureihe

BTL5 Compact Rod

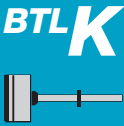
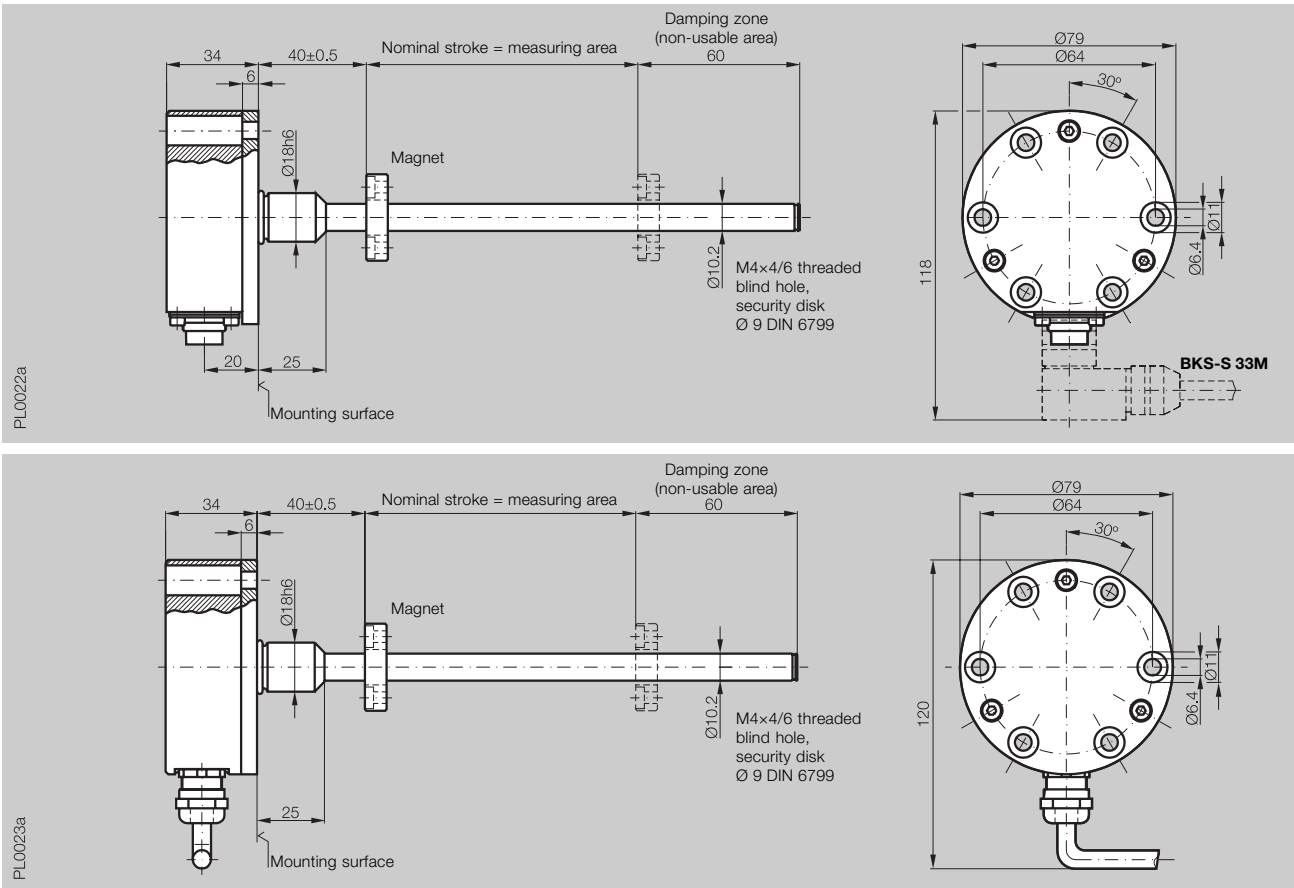

General data Installation notes

Analog interface
Digital pulse interface
SSD interface

Ordering code	BTL5-...-M-...-K-
Shock load	100 g/6 ms per IEC 68-2-27 and 100 g/2 ms per IEC 68-2-29
Vibration	12 g, 10...2000 Hz per IEC 68-2-6
Polarity reversal protected	yes
Oversvoltage protection	Transzorb protection diodes
Dielectric strength	500 V (ground to housing)
Enclosure rating per IEC 529	IP 67 (when BKS-S32/33 is installed); IP 68, 5 bar for cable version
Housing material	1.4305 stainless
Flange and tube material	tube: 1.4571 stainless, flange: 1.4571 or 1.4429 or 1.4404
Housing attachment	flange with 6 mounting holes
Connection type	connector or integral cable
Recommended connector see p. B.3	BKS-S 32M/BKS-S 32M-C/BKS-S 33M
EMC testing:	
RF emission	EN 55 011 Group 1, Class A
Static electricity (ESD)	IEC 1000-4-2 Severity Level 3
Electromagnetic fields (RFI)	IEC 1000-4-3 Severity Level 3
Fast transients (BURST)	IEC 1000-4-4 Severity Level 4
Line carried noise, induced by high-frequency fields	IEC 1000-4-6 Severity Level 3
Standard nominal strokes [mm]	0025, 0050, 0075, 0100, 0125, 0150, 0175, 0200, 0225, 0250, 0275, 0300, 0325, 0350, 0375, 0400, 0425, 0450, 0475, 0500, 0550, 0600, 0650, 0700, 0750, 0800, 0850, 0900, 0950, 1000, 1100, 1200, 1300, 1400, 1500, 1600, 1700, 1800, 1900, 2000, 2250, 2500, 2750, 3000, 3250, 3500, 3750, 3850 or in 5 mm increments on request

- Included:
- Transducer (see starting page **K.4** for interface options)
 - User's Guide

Please order separately:
Magnets page **B.14**
Floats page **B.15**
Connectors page **BKS.3**



Page **BKS.3**

An integrator circuit provides resolution of better than 0.1 mV.

BTL transducers with analog outputs are available for 0...10 V, 4...20 mA, 0...20 mA and -10...10 V as rising or falling signals.

Outputs

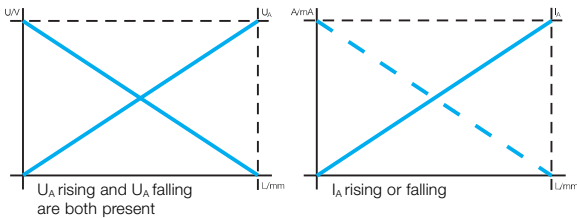

Compensating the output signal

max. 15 % of the nominal stroke in the direction of the rod end.

BTL transducers with analog output have two potentiometers for adjusting the null and endpoint to the particular application. The nullpoint can be shifted by

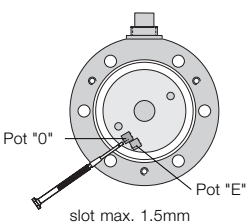
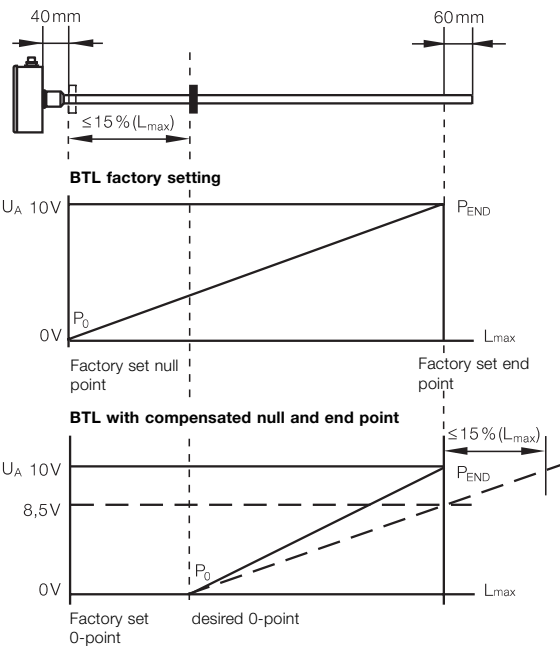

Location of trim pots with cover removed

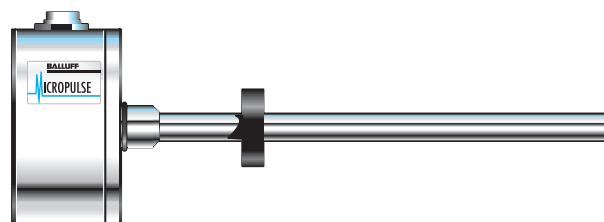

Series
Output signal
Transducer interface
Input interface

Ordering code

Output voltage
Output current
Load current
max. ripple
Load resistance
System resolution

Hysteresis
Repeatability
Internal sampling frequency
max. non-linearity

Temperature coefficient	Voltage output
	Current output

Operating voltage
Current draw
Polarity reversal protected
Overvoltage protection
Dielectric constant
Operating temperature
Storage temperature

Pin assignments	Pin	Color
Output signals	1	YE
	2	GY
	3	PK
	5	GN
Supply voltage	6	BU
	7	BN
	8	WH

Connect shield to housing.

Compact Rod **Micropulse Transducers**

Analog interface
Compact rod series

BTL5 Compact Rod analog A analog	BTL5 Compact Rod analog E analog	BTL5 Compact Rod analog C analog	BTL5 Compact Rod analog G analog
---	---	---	---

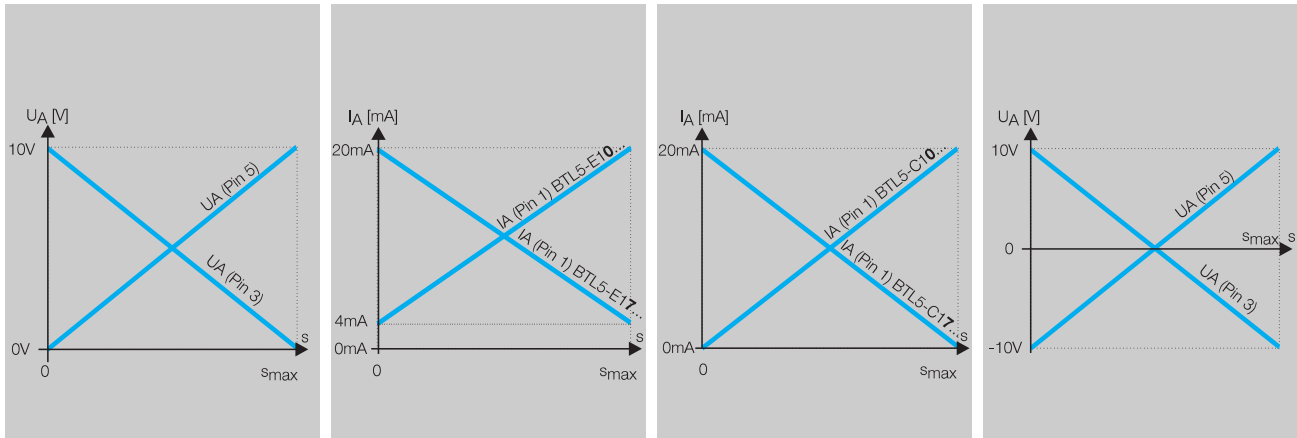

BTL5- A 11-M___-K-___	BTL5- E 1_-M___-K-___	BTL5- C 1_-M___-K-___	BTL5- G 11-M___-K-___
------------------------------	------------------------------	------------------------------	------------------------------

0...10 V and 10...0 V	4...20 mA or 20...4 mA	0...20 mA or 20...0 mA	-10...10 V and 10...-10 V
max. 5 mA ≤ 5 mV	≤ 500 Ohms ≤ 0.2 μA	≤ 500 Ohms ≤ 0.2 μA	max. 5 mA ≤ 5 mV
≤ 0.1 mV			≤ 0.1 mV

≤ 4 μm			
System resolution/min. 2 μm			
$f_{\text{STANDARD}} = 1 \text{ kHz}$			
±100 μm up to 500 mm nominal stroke			
±0.02 % 500...4000 mm nominal stroke			
$[150 \mu\text{V}/^\circ\text{C} + (5 \text{ ppm}/^\circ\text{C} \times P \times U/L)] \times \Delta T$			
$[0,6 \mu\text{A}/^\circ\text{C} + (10 \text{ ppm}/^\circ\text{C} \times P \times I/L)] \times \Delta T$			
24 V DC ±20 %			
≤ 150 mA			
yes			
Transzorb protection diodes			
500 V (Ground to housing)			
-40...+85 °C			
-40...+100 °C			

BTL5- A 11...	BTL5- E 10...	BTL5- E 17...	BTL5- C 10...	BTL5- C 17...	BTL5- G 11...
0 V output	4...20 mA	20...4 mA	0...20 mA	20...0 mA	0 V output
10...0 V	0 V output	10...0 V	0 V output	10...0 V	10...-10 V
0...10 V	0...10 V	0...10 V	0...10 V	0...10 V	-10 ... 10V
GND	GND	GND	GND	GND	GND
+24 V DC	+24 V DC	+24 V DC	+24 V DC	+24 V DC	+24 V DC

► Please enter code for output signal, nominal stroke and connection type in ordering code!

► Included:
– Transducer
– User's Guide

Please order separately:
Magnets page **B.14**
Floats page **B.15** and **Ex.6**
Connectors starting page **BKS.3**

Ordering example:

BTL5-E1_-M___-K-___

Output signal	Standard nominal strokes [mm]	Connection type
1 rising and falling (for A and G)	0025, 0050, 0075, 0100, 0125, 0150, 0175, 0200, 0225, 0250, 0275, 0300, 0325, 0350, 0375, 0400, 0425, 0450, 0475, 0500, 0550, 0600, 0650, 0700, 0750, 0800, 0850, 0900, 0950, 1000, 1100, 1200, 1300, 1400, 1500, 1600, 1700, 1800, 1900, 2000, 2250, 2500, 2750, 3000, 3250, 3500, 3750, 3850, 4000 or in 5 mm increments on request	SR32 connector K02 PUR cable 2 m K05 PUR cable 5 m K10 PUR cable 10 m K15 PUR cable 15 m
0 rising		
7 falling (for C and E)		



General data
Installation notes
Analog interface
Digital pulse interface
SSD interface



Page **BKS.3**

P-Interface

Compatible with BTA processors and various OEM controls, e. g., Siemens, Schleicher, B & R, Mitsubishi, Schiele, Parker, Esitron, Philips, Fanuc and others.

Reliable signal transmission, even over cable lengths up to 500 m between BTA and BTL, is assured by the especially noise-immune RS485 differential drivers and receivers. Noise signals are effectively suppressed.

I-Interface

Used for parallel operation of multiple transducers, for example up to 4 transducers can be operated by a single BTA-M/PMT card (see page **BTA.2**).

short and economical

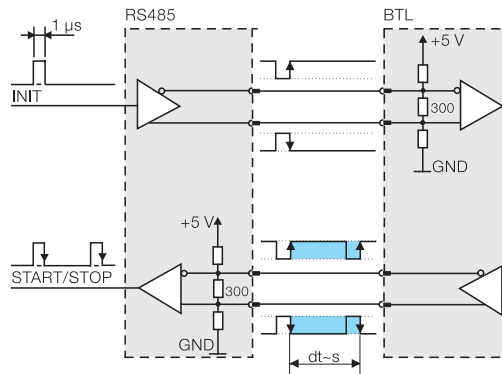

Block diagram of P interface

Highly precise digitizing of the P-interface signal

Companies developing their own control and processing electronics can create a highly accurate P-interface cost effectively and with a minimum of effort using the Balluff digitizing chip. The digitizing chip was developed as a high-resolution, configurable ASIC for the Micropulse P-interface.

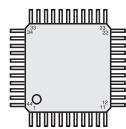

Digitizing chip 44QFP

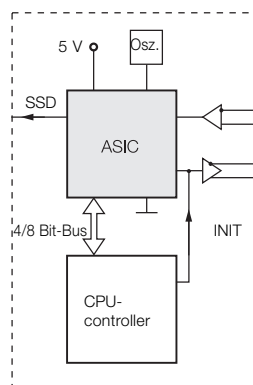

Controller or processing electronics

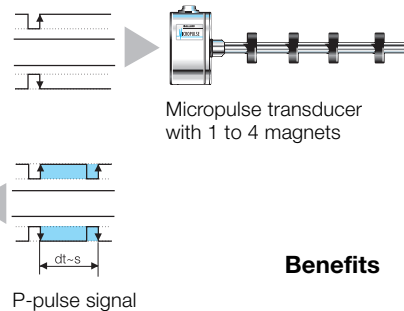

Micropulse transducer with 1 to 4 magnets

Benefits

- High resolution: The 2 μm actual resolution of the BTL transducer is fully supported by the 5 μm resolution of the chip (at low clock frequency 2 or 20 MHz)
- Position data from 4 magnets can be processed simultaneously
- 4/8-bit processor interface

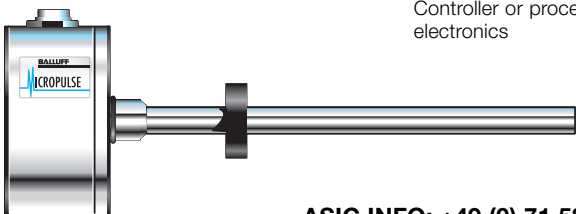

ASIC INFO: +49 (0) 71 58/1 73-2 41

Compact Rod **Micropulse Transducers**

Digitale pulse interface
Compact rod series

Series	BTL5 Compact Rod	BTL5 Compact Rod
Transducer interface	Pulse P	Pulse I
Input interface	Pulse P	Pulse I

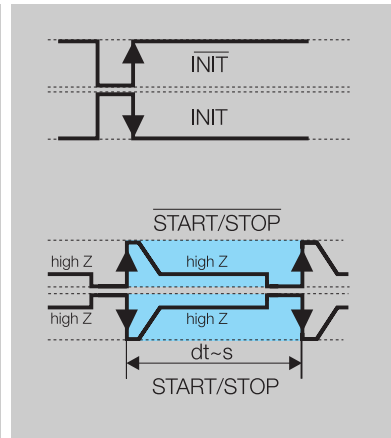
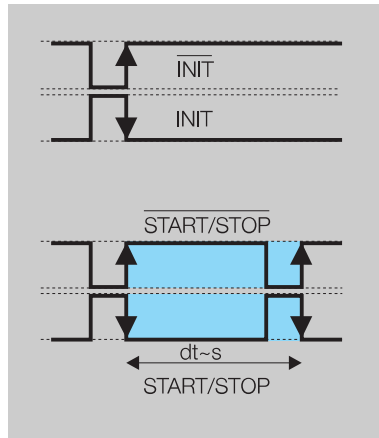

Ordering code	BTL5-P1-M ___ -K- ___	BTL5-I1-M ___ -K- ___
System resolution	processor dependent	
Repeatability	2 µm or 1 digit depending on processing	
Resolution	≤ 2 µm	
Hysteresis	≤ 4 µm	
Internal sampling rate	f _{STANDARD} = 1 kHz = ≤ 1400 mm	
max. non-linearity	±100 µm up to 500 mm nominal stroke ±0.02 % 500...4000 mm nominal stroke	
Temperature coefficient of overall system	(6 µm +5 ppm × L)/°C	
Operating voltage	24 V DC ±20 %	
Current draw	≤ 100 mA	
Operating temperature	-40...+85 °C	
Storage temperature	-40...+100 °C	

Pin assignments	Pin	Color	BTL5-P1-M...	BTL5-I1-M...
Input/output signals	Input	1	YE	INIT
	Ouptut	2	GY	START/STOP
	Input	3	PK	INIT
	Ouptut	5	GN	START/STOP
Supply voltage		6	BU	GND
		7	BN	+24 V DC
		8	WH	

Shield connected to housing.

► Please enter code for nominal stroke and connection type in ordering code!

► Included:
– Transducer
– User's Guide

Please order separately:
Magnets page **B.14**
Floats page **B.15** and **Ex.6**
Connectors starting page **BKS.3**

Ordering example:

BTL5-P1-M ___ -K- ___

Standard nominal strokes [mm]

0025, 0050, 0075, 0100, 0125, 0150, 0175, 0200, 0225, 0250, 0275, 0300, 0325, 0350, 0375, 0400, 0425, 0450, 0475, 0500, 0550, 0600, 0650, 0700, 0750, 0800, 0850, 0900, 0950, 1000, 1100, 1200, 1300, 1400, 1500, 1600, 1700, 1800, 1900, 2000, 2250, 2500, 2750, 3000, 3250, 3500, 3750, 3850, 4000 or in 5 mm increments on request

Connection type

SR32 connector
K02 PUR cable 2 m
K05 PUR cable 5 m
K10 PUR cable 10 m
K15 PUR cable 15 m

BTLK



General data
Installation notes
Analog interface
Digital pulse interface
SSD interface

BKS



Page **BKS.3**

BTA



Page **BTA.2**

SSD Interface

Synchronous serial data transmission for controls made by Siemens, Schleicher, B & R, PEES, Schiele, Parker, Esitron etc. as well as for Balluff BDD-AM 10-...-1-SSD and BDD-CC 08-1-SSD display/controllers.

Reliable signal transmission, even over cable lengths of up to 400 m between control and BTL transducer is assured by especially noise-immune RS485/422 differential line drivers and receivers. Any noise signals are effectively suppressed.

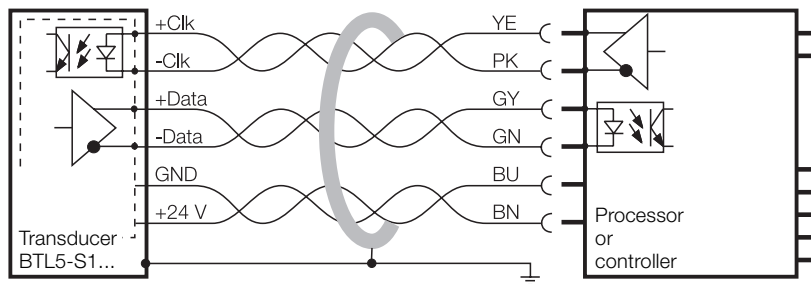

BTL5-S1... with processor/controller, wiring example

Clock frequency depends on cable length

Cable length	Clock freq.
< 25 m	< 1000 kHz
< 50 m	< 500 kHz
< 100 m	< 400 kHz
< 200 m	< 200 kHz
< 400 m	< 100 kHz

Super-fast 2 kHz Sampling rate

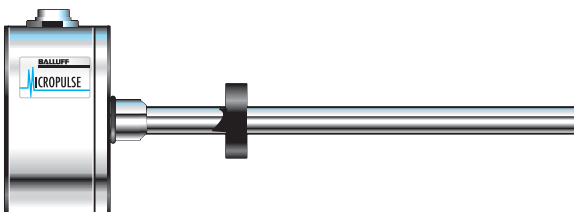

Series	BTL5 Rod
Output signal	synchronous serial
Transducer interface	S
Input interface	synchronous serial

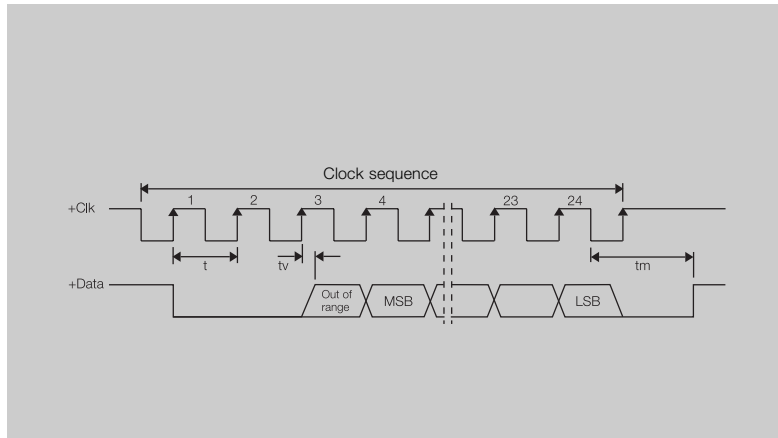

Ordering code	BTL5-S1_-M_-K-S 32
---------------	---------------------------

Repeatability	±1 digit
System resolution depends on version (LSB)	1, 5, 10, 20 or 40 µm
Hysteresis	≤ 1 digit
Internal sampling frequency	f _{STANDARD} = 2 kHz
max. non-linearity	±30 µm at 1.5 and 10 µm resolution or ≤ ±2 LSB
Temperature coefficient of overall system	(6 µm + 5 ppm × L) / °C
Operating voltage	24 V DC ±20 %
Current draw	≤ 80 mA
Operating temperature	-40...+85 °C
Storage temperature	-40...+100 °C

Pin assignments	Pin	Color	
Control and data signals	1	YE	+Clk
	2	GY	+Data
	3	PK	-Clk
	5	GN	-Data
Supply voltage (external)	6	BU	GND
	7	BN	+24 V DC
	8	WH	must remain unconnected



General data
Installation notes
Analog interface
Digital pulse interface
SSD interface

► Please enter code for coding, system resolution, nominal stroke and connection type in ordering code!

Ordering example:

BTL5-S1_-M_-K-

Coding	System resolution	Standard nominal strokes [mm]	Connection type
0 Binary code rising (24 bits)	1 1 µm	0025, 0050, 0075, 0100,	SR32 connector
1 Gray code rising (24 bits)	2 5 µm	0125, 0150, 0175, 0200,	K02 PUR cable 2 m
6 Binary code rising (25 bits)	3 10 µm	0225, 0250, 0275, 0300,	K05 PUR cable 5 m
7 Gray code rising (25 bits)	4 20 µm	0325, 0350, 0375, 0400,	K10 PUR cable 10 m
	5 40 µm	0425, 0450, 0475, 0500,	K15 PUR cable 15 m
		0550, 0600, 0650, 0700,	
		0750, 0800, 0850, 0900,	
		0950, 1000, 1100, 1200,	
		1300, 1400, 1500, 1600,	
		1700, 1800, 1900, 2000,	
		2250, 2500, 2750, 3000,	
		3250, 3500, 3750, 3850,	
		4000 or in 5-mm increments on request.	

► Included:
- Transducer
- User's Guide

Please order separately:
Magnets page **B.14**
Floats page **B.15**
Connectors starting page **BKS.3**



Page **BKS.3**

